

The TR 490 tripod turnstile is designed for an economic and dissuasive access control and can incorporate access control devices such as: card readers, coin/token acceptors, ticketing systems, etc ...

Its mechanical design is strong and reliable allowing 20 different configurations to suit all architectural requirements in terms of pedestrian access control.

Description

1. Stainless steel sheet frame.
2. Front and rear sections made of stainless steel locked from inside. These sections can not be opened before upper cover removal. They are designed to incorporate user control equipment such as card reader, coin acceptor, proximity reader, etc.
3. Upper cover in stainless steel with lock, to ease access to the turnstile mechanism and to open the columns.
4. Tripod turnstile mechanism with solid steel arms and capstan on ball bearings, protected by a black PVC hub cover.
Electromagnetically operating locking bolts mounted on self lubricating bearings to lock arms.
Hydraulic adjustable pressure movement shock absorber ensuring silent smooth operation and progressive slowing down of the arm rotation even when used with force.
Reversed rotation prevented by the anti pass back device.
5. Stainless steel arms with locking device preventing the arm from being removed without appropriate tools.
6. Programmable electronic control logic TR6 (see relevant Technical Data Sheet)
7. Each gate is designed to accommodate an orientation pictogram display in one or both directions (optional)
8. Floor fixing by means of expansible plugs.

Operation

The TR 490 turnstile can operate in 5 different modes.

1. Access permanently free
2. Access permanently mechanically locked
3. Access mechanically locked with automatic unlocking device to give free passage in case of power failure. (Free-rotation)
4. Electrically controlled access
5. Access electrically controlled with automatic unlocking device to give free passage in case of power failure. (Free-rotation)

The operation mode is defined by specifying the code number above for both directions, which corresponds to the operation selected.

Conventions:

Direction A = housing at right hand side of the walkway

Direction B = housing at left hand side of the walkway

Example:

Turnstile free in direction A and electrically controlled in direction B with automatic unlocking device: this is a TR 490 AI-B5 type turnstile.

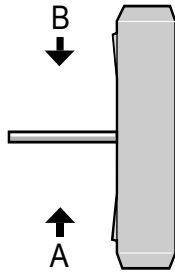

Anti-corrosion

Internal mechanical parts are treated by yellow electrozinc bichromate.

Technical specifications

- Power supply: 230V single phase 50/60 Hz
- Control circuit: 24V DC
- Electromagnet: duty cycle 100%
- Consumption: 30W
- Shock absorber: hydraulic
- Operating temperatures: 0° to + 50°C
- Net weight: 82 Kg
- This equipment is IP40

Options

- 120 V 60 Hz single phase version
- Cut out in the front and rear end sections to integrate the customer's control equipments, according to dimensions and positioning to be communicated (maximum width: 190 mm, maximum depth: 200 mm)
- Counting device per walkway and per controlled direction, with reset or not, electrically or mechanically controlled
- Orientation pictogram with red cross and green arrow (see technical data sheet: Doc-Picto-FT-UK)
- Function pictograms indicating authorization of passage (see technical data sheet: Doc-Picto-FT-UK)
- Heating resistance for use in -20 °C environments
- Token or coin acceptor integrated in feet
- Closure between feet in stainless sheet
- Painted steel central housing - RAL to be specified

Work to be provided by the customer

- 230 V single phase power supply, 6A + Ground
- Connecting electrical wiring to the control units
- Possible masonry and fixing work (see installation plan n° CH 3668 GB)

Dimensions

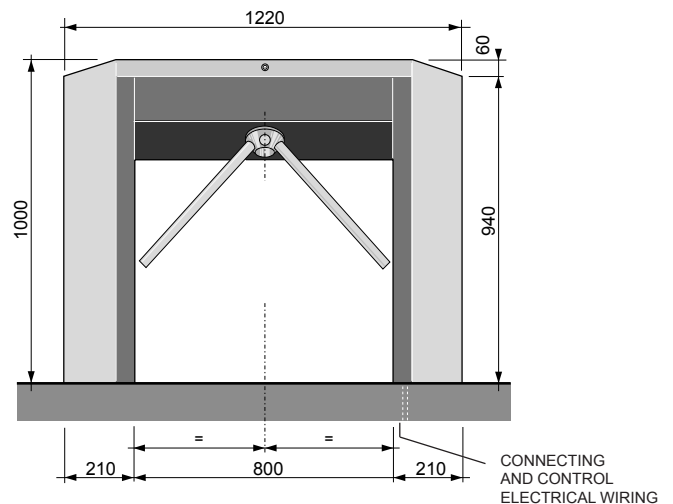
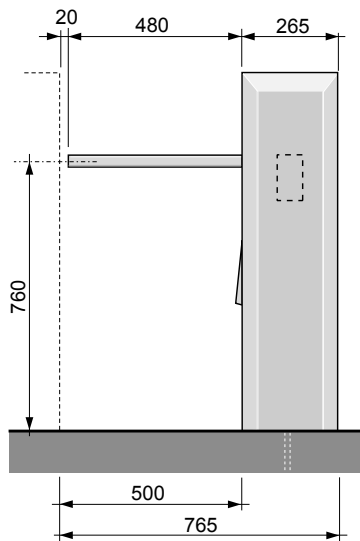

Our dealer



Av. Mercator 5 B-1300 Wavre Belgium
 Tel. +32 10 23 02 11 / Fax +32 10 23 02 02
 asmail@automatic-systems.com
 www.automatic-systems.com



With a constant view of adopting the latest technological developments, Automatic Systems reserves the right to amend the information above, at any time.