

Description

1. High rigidity self-supporting frame, integrating an electromechanical drive, users' passage safety sensors and electronic control units.
2. Lateral panels on the side opposite to the obstacle made of painted steel (standard colour available: RAL5018 Turquoise blue. Other colors as options.)
3. Front and rear end sections made of 1,5 mm thick brushed finish stainless steel sheet. Element designed to accept access control systems (proximity cards and ticket readers...).
4. Obstacle made of 12 mm thick clear tempered safety glass. Standard height from floor: 930 mm.
5. Stainless steel doors on both sides of the obstacle giving access to the gate electromechanical assembly. Fitted with locks.
6. Electromechanical assembly containing:
 - one asynchronous three-phase geared motor with an electromagnetic brake,
 - A transmission system with notched belts and pulleys.
 - two crankshaft-rod mechanisms to ensure smooth movements cushioned in the three stable positions, as well as the mechanical locking of the obstacle in closed and open position,
 - unlocking device of the obstacle with return spring to ensure automatic opening of the gate in case of power failure (standard version opens in B direction).
7. Programmable control logic ensuring the motor operation, comprising:
 - one programmable control board,
 - one variable speed controller,
 - one general connection block,
 - 24V DC power supply.
8. User orientation and/or information display kit available as option.
9. Protection cells: in case of detection, they stop the movement of the obstacle when closing. Other functionalities are programmable: stop when opening, reopen after stopping,... If the PMD is not associated with a PNG, there must be a reflecting strip facing the obstacle.

A similar "UL" compliant equipment is available

The fully motorized, bi-directional pedestrian gate, PMD 335, is designed as an accessible passageway to accommodate the disabled, people with carts or other authorized users requiring a wider walkway than a standard automatic gate. The pedestal coordinates with the PNG 380. The PMD operates in both entrance and exit directions, opening in the direction of the user's movement.

Its particularly elaborate design makes it easily adaptable to any type of architectural environment. All materials used have been carefully selected for their resistance, endurance and safety qualities, the result of Automatic Systems' engineering experience accumulated for many years.

The PMD is an effective deterrent to fraudulent entry as the gate is mechanically and electronically locked in the closed position. In the open position, the safety glass panel is completely recessed alongside the cabinet providing a comfortable walkway, as well as excellent safety egress. The gate has a fail-safe device that moves it to the open position during power failure.

Protection cells and electronic torque limiter effectively ensure the user's safety during his passage.

Anti-corrosion treatment

All mechanical parts have been treated against corrosion by electrozinc dichromate and/or cathaphoresis.

Technical characteristics

- Electrical power supply: 230V single-phase, 50/60Hz
- Geared motor : 0,12 kW
- Speed reduction gearbox : reversible type, life-lubricated
- Power consumption: at rest = 50 W,
operating = 150W
- Operation temperature: from -10° to + 45°C
- Net weight : ±140 kg
- This equipment is IP40

Conventions

Direction A = housing at the right hand side of the walkway
 Direction B = housing at the left hand side of the walkway

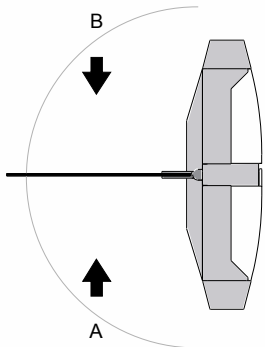

Dimensions

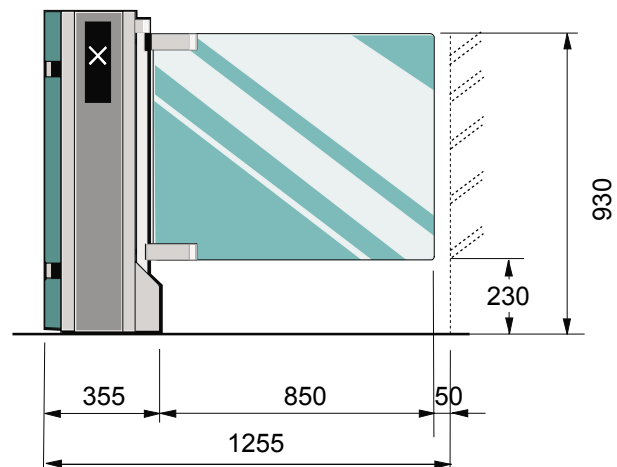
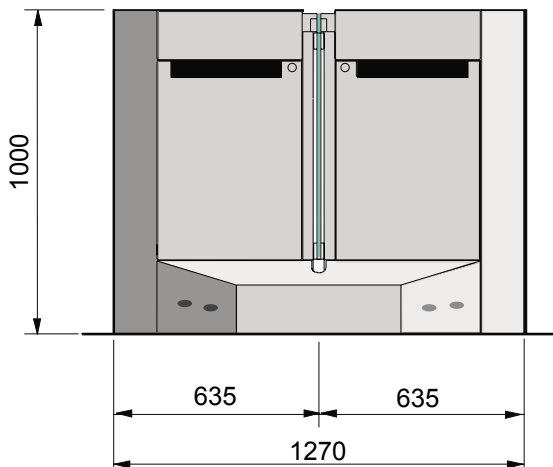

Options

- 120V - 60Hz - single phase version
- User orientation pictograms (see technical data sheet: Doc-Picto-FT-UK)
- User information pictograms (see technical data sheet: Doc-Picto-FT-UK)
- Out-of-standard height of obstacles (1200, 1400, 1700, 1900 mm).
- Customising of front and rear elements for integrating access control or badge reader systems.
- Out-of-standard RAL colours for side doors (reference number to be supplied with order).
- Stainless steel side doors
- Master-slave operation.
- Sandblasting of logo on mobile and/or fixed glass.
- Heating system for use in -20°C environments

Work to be provided by the customer

- 230V AC, 50/60 Hz, 10A power supply.
- Electrical power supply and connection wiring to the controls (see installation plan n° CH3882).
- Possible masonry work

Our dealer

automatic[®]
systems

Av. Mercator 5 B-1300 Wavre Belgium
 Tel. +32 10 23 02 11 / Fax +32 10 23 02 02
 asmail@automatic-systems.com
 www.automatic-systems.com

VER Group



With a constant view of adopting the latest technological developments, Automatic Systems reserves the right to amend the information above, at any time.